



TUGS & TOW TRACTORS: Electric Tugger

- ▲ Applications: For moving any rolling objects such as Dolleys, Trolleys & Roll Cages in warehouses, workshops, supermarkets etc...
- ▲ Can be used in a wide variety of applications.
- ▲ Very compact design makes the machine extremely manoeuvrable and very easy to take it with you in bus, car or truck or any vehicles.
- ▲ Very easy to connect the hook to the object in an instant with almost no effort.
- ▲ High quality Curtis Speed Controller, which is programmable according to your needs.
- ▲ Motivated employers and more productivity.
- ▲ Special designs are acceptable for special applications.



Article No.	MP-50	MP-75	MP-100
Load capacity (kg)	500	750	1000
Driving Speed (km/h)		0—6	
Driving Motor (v/w)	DC24/400	DC24/400	DC24/400
Brake system		Electromagnetic	
Battery (v/Ah)	2*DC12V / 40Ah	2*DC12V / 70Ah	2*DC12V / 70Ah
Charger (v/Ah)	24V/10	24V/10	24V/10
Wheels	Pneumatic Driving w heel, Rear PU		
Handle	Multi-fuction		

TUGS & TOW TRACTORS: Electric Tugger

- ▲ High quality Curtis Speed Controller, which is programmable according to your needs.
- ▲ Motivated employers and more productivity.
- ▲ Special designs are acceptable for special applications.

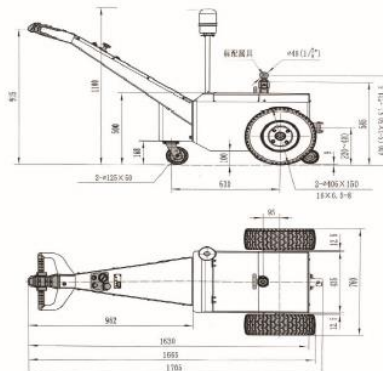

Load capacity (kg)	2000
Driving Speed (km/h)	4—5
Driving Motor (v/w)	DC24/400
Brake system	Electromagnetic
Battery (v/Ah)	2*DC12V / 100Ah
Charger (v/Ah)	24V/15
Wheels	Pneumatic Driving w heel, Rear PU
Handle	Multi-fuction